



Residual Life and Durability Analysis of Aerospace Components

Ramesh Chandwani – Zentech International Limited, UK.
Presented at IoM3 On an AM in Defence Event on 21 Nov 2024.

zentech.co.uk

Historical perspective – Residual Life & Durability in Aerospace

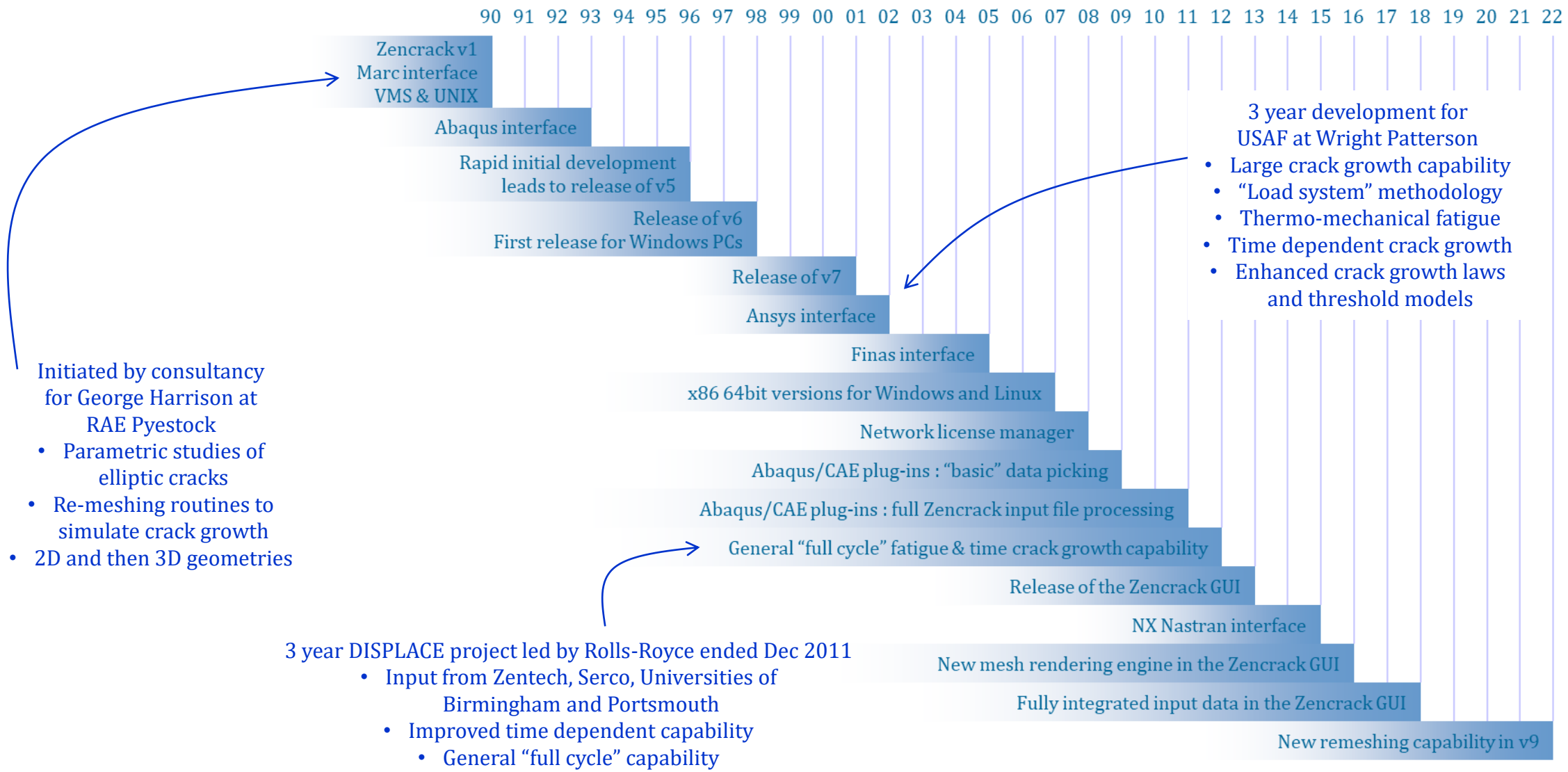

Key areas for FM based crack propagation simulation

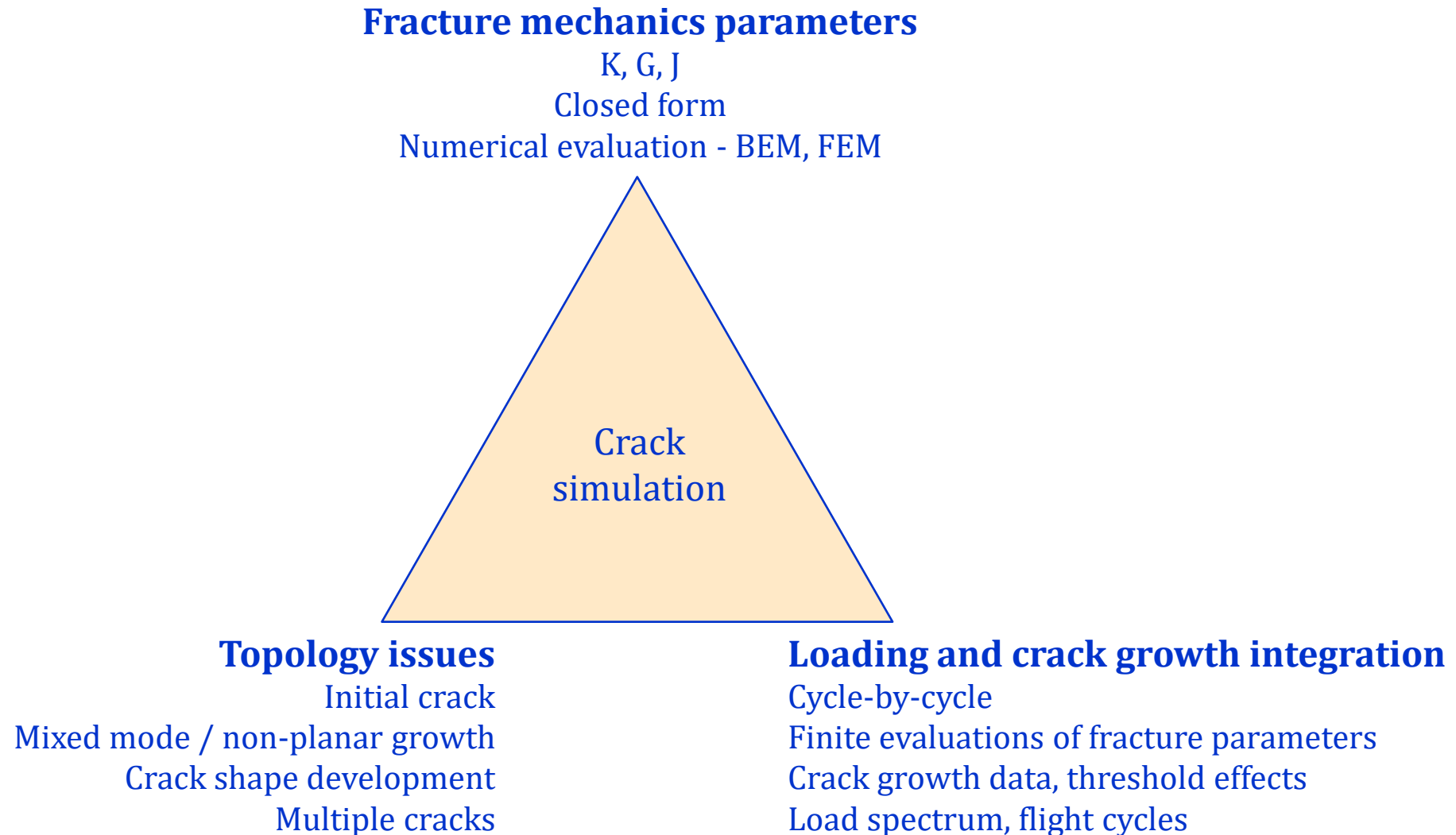

The solution available from Zentech: Zencrack

- Zencrack:
 - Is a powerful tool for fracture mechanics analyses
 - Uses commercially available finite element codes as the solution engine to help calculate fracture mechanics parameters:
 - » Abaqus/Standard
 - » Ansys/Mechanical APDL
 - » Simcenter Nastran (previously NX Nastran)
 - Has meshing algorithms and generalised approaches for modelling crack fronts to help minimise topology related issues
 - Has a crack growth integration scheme to allow generalised non-planar crack growth prediction

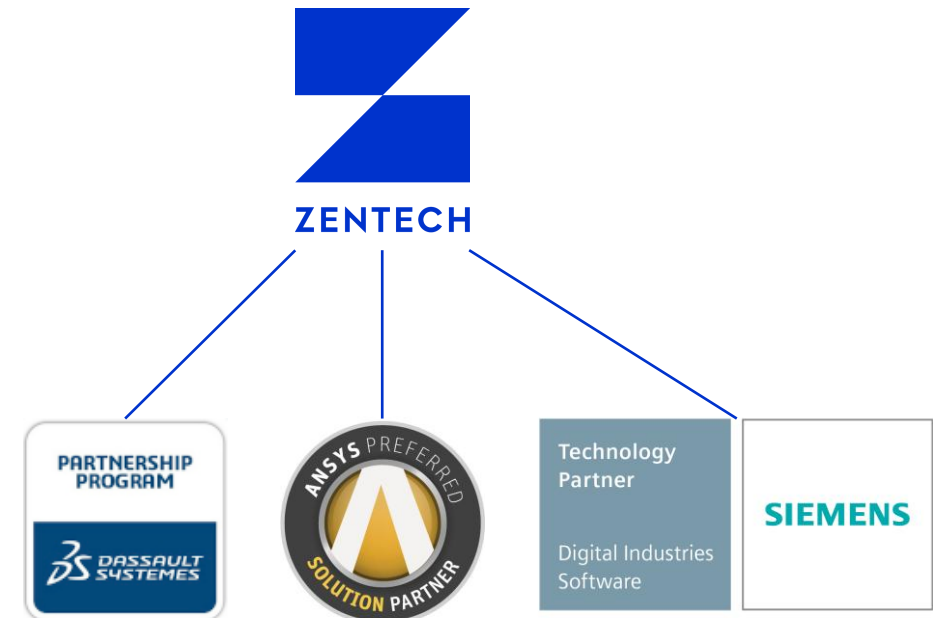
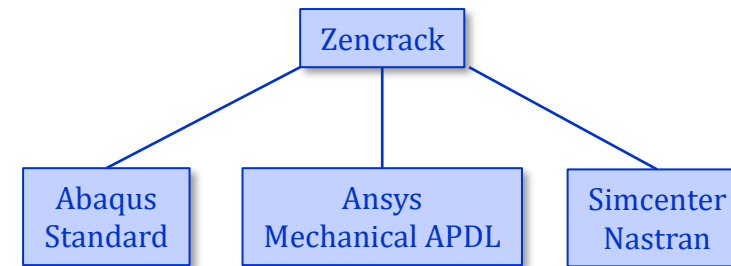

The solution provided by Zencrack

- A fast and easy means of analysing cracks in 3D components under arbitrary loading
 - Static load cases
 - Thermal transients
 - Thermo-mechanical time-varying loads
 - Multiple cracks
- A general purpose 3D crack growth simulation capability
 - Non-planar crack growth
 - Fatigue loading
 - » Constant amplitude to complex thermo-mechanical load cycles
 - Time dependent loading

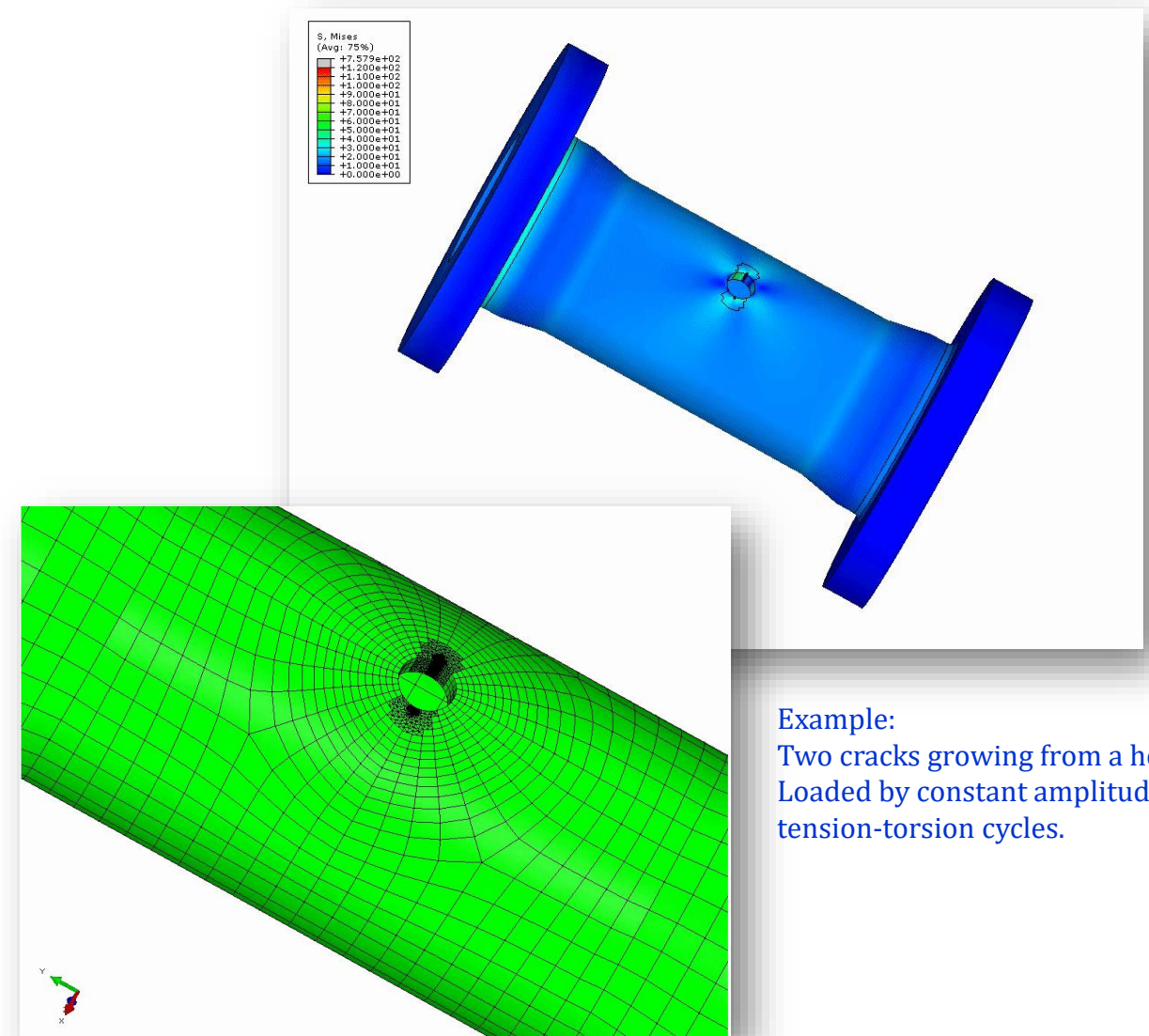

Summary of Zencrack workflow

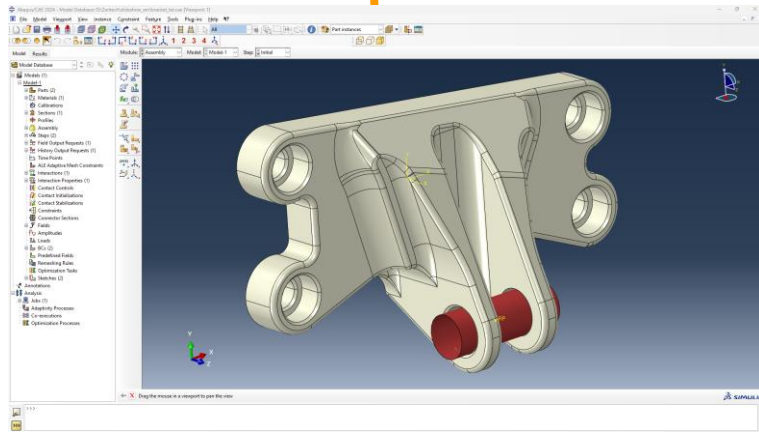

F.E. pre-processing

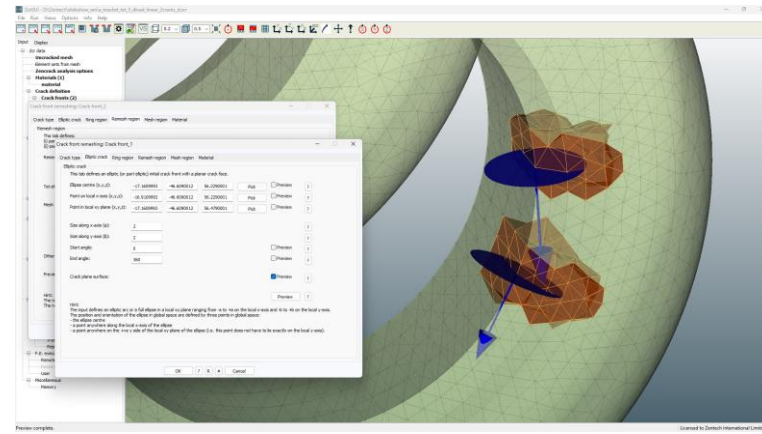

Zencrack pre-processing

USER INPUT
An existing f.e. mesh of an uncracked component

USER INPUT
Additional data e.g. crack location, size, growth law, load history

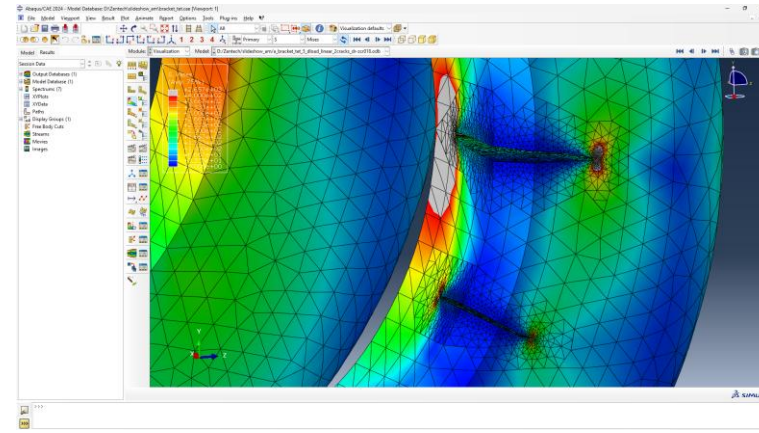
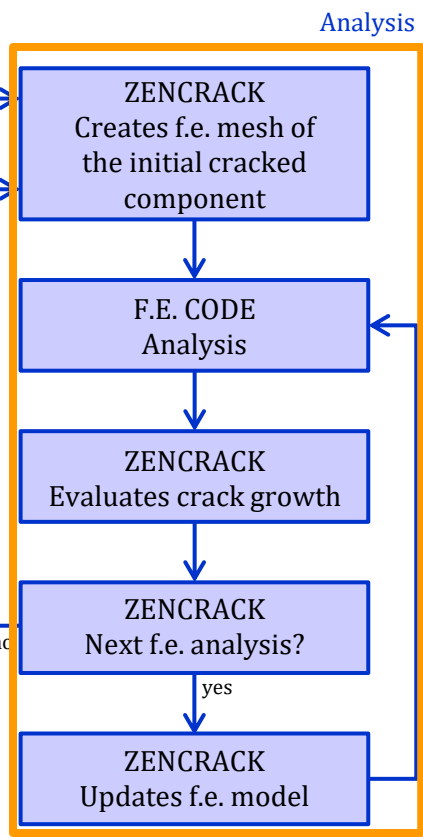

F.E. post-processing

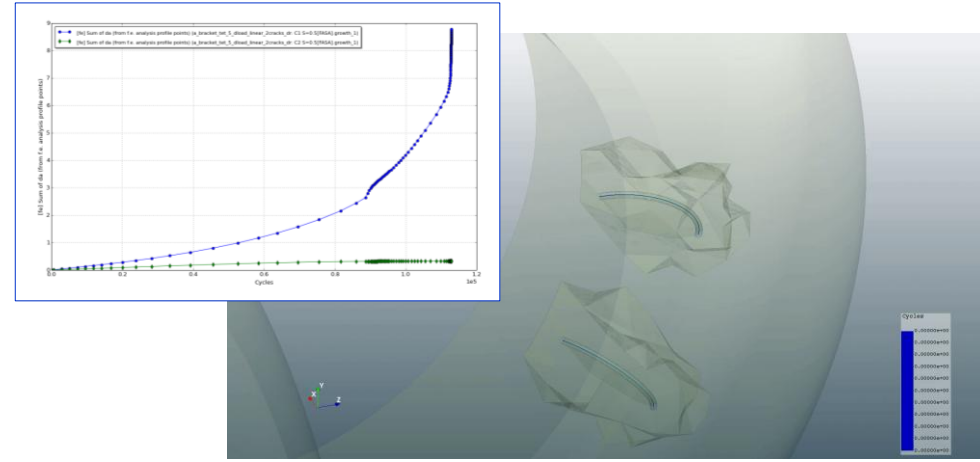

Zencrack post-processing

Life extension, durability & damage tolerance assessment

- Engine disks, blades and their dovetail connections
- Power generation components
- Pipeline defects
- Welded connections
- Stiffened panels (integral & riveted)
- Adhesive bonded joints / patch repairs
- Additive manufactured components

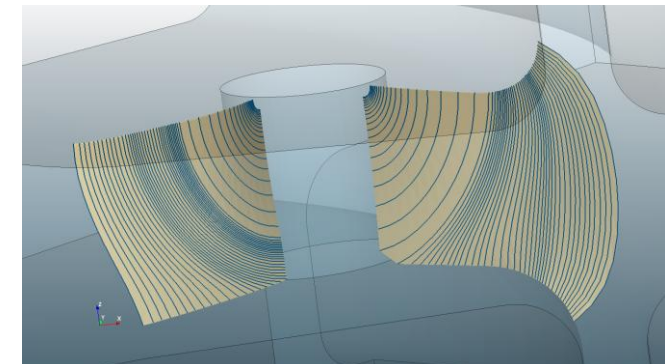
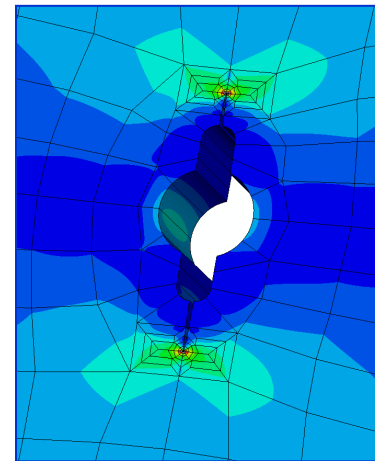
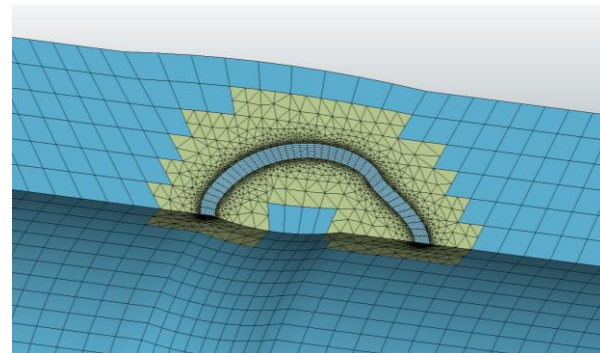
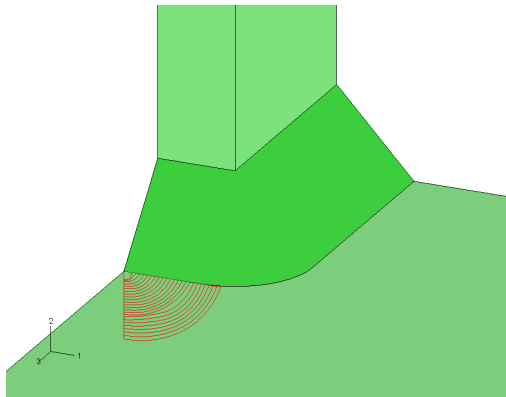
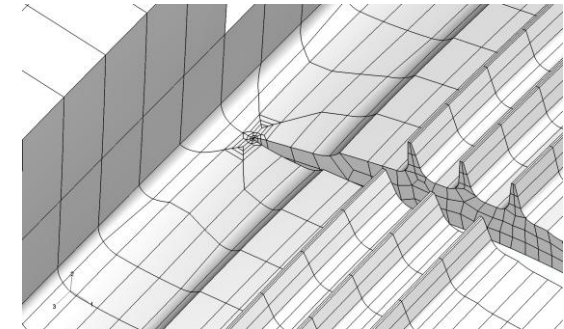
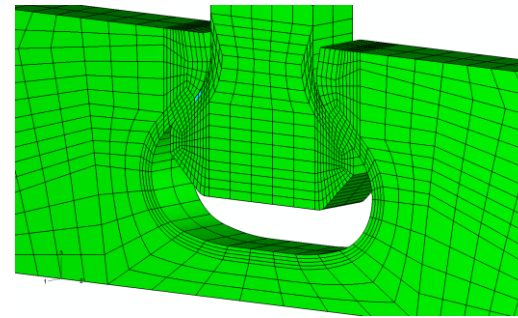
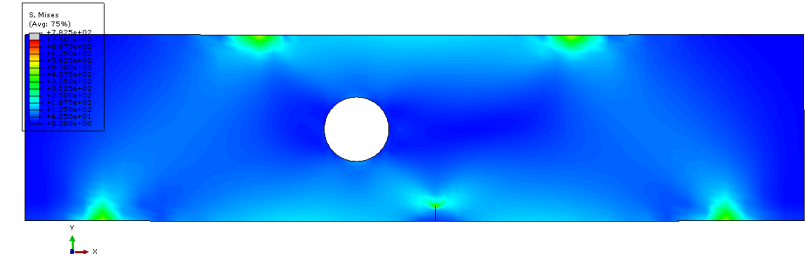

Remeshing procedure

- Geometry-based initial crack definition and preview in the Zencrack GUI
- Optional preview of the initial cracked mesh

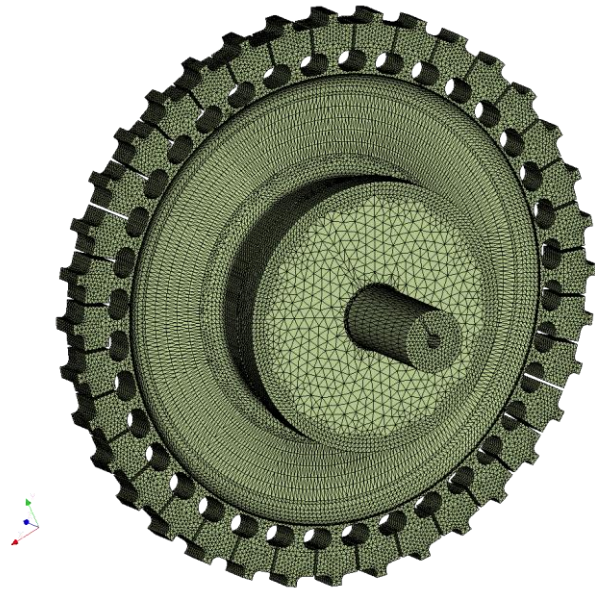

Example - Minidisk

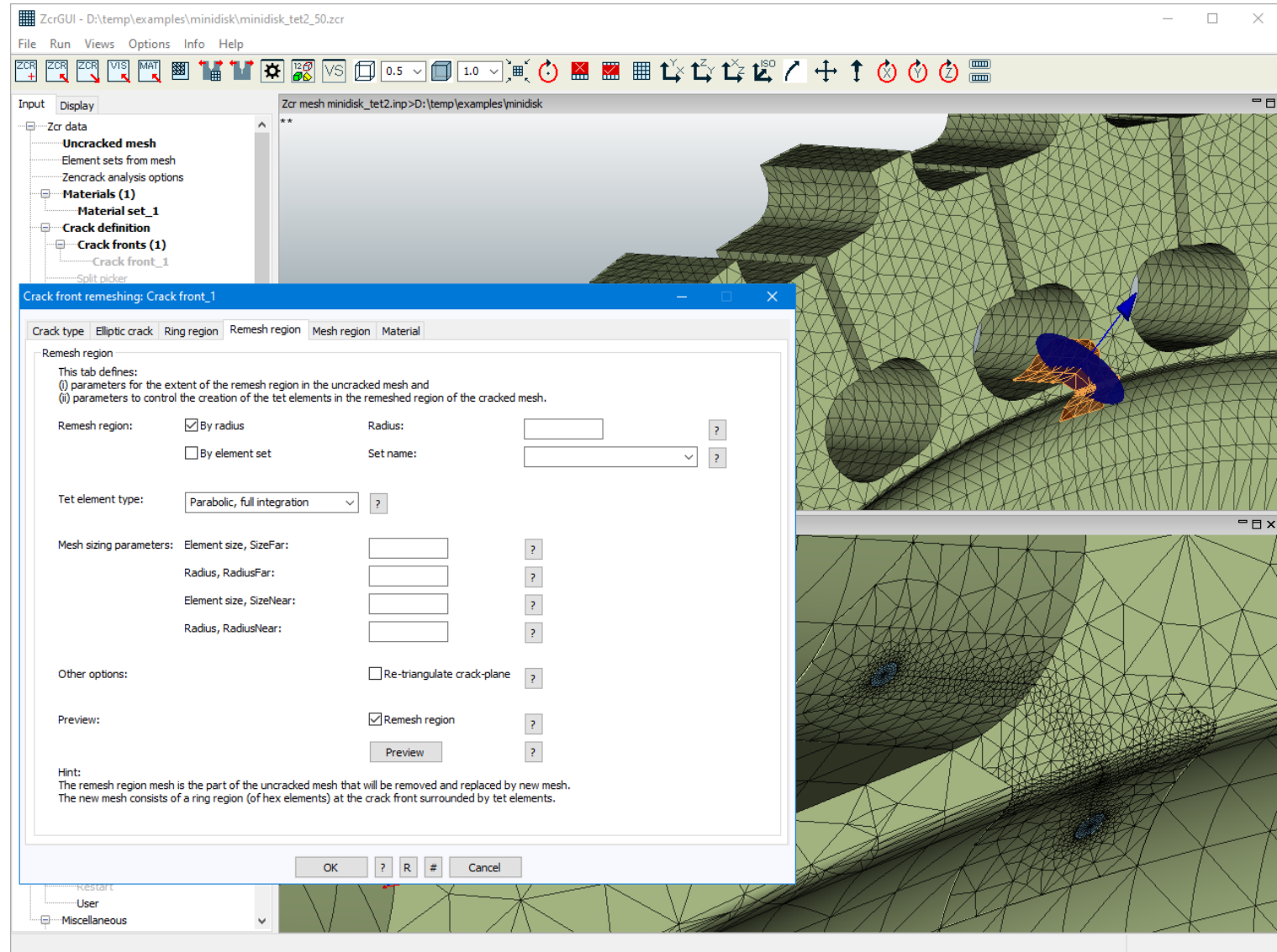

Zencrack GUI – Post-processing – crack profiles

- Import crack surface and growth profiles from Zencrack analyses
- Display crack profiles and surfaces
 - Set display attributes such as contouring, colour, labelling of profiles etc.
- Results from multiple jobs can be overlaid to aid comparison
- Surfaces and profiles may be superimposed on a mesh

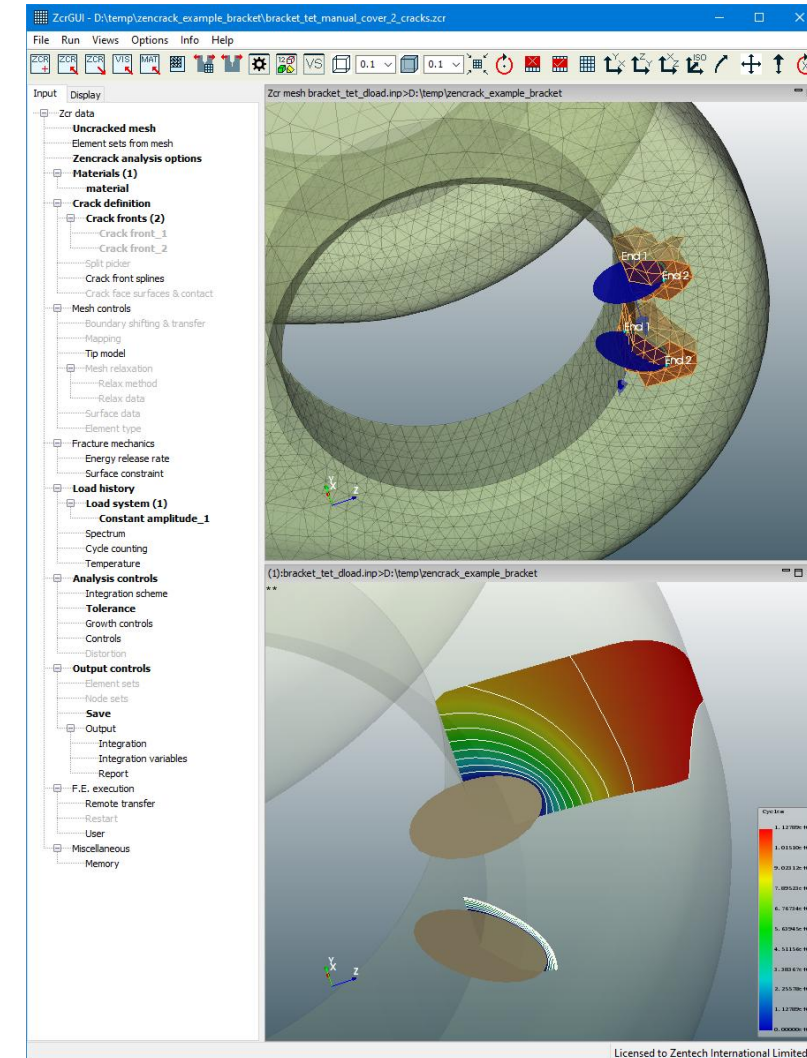
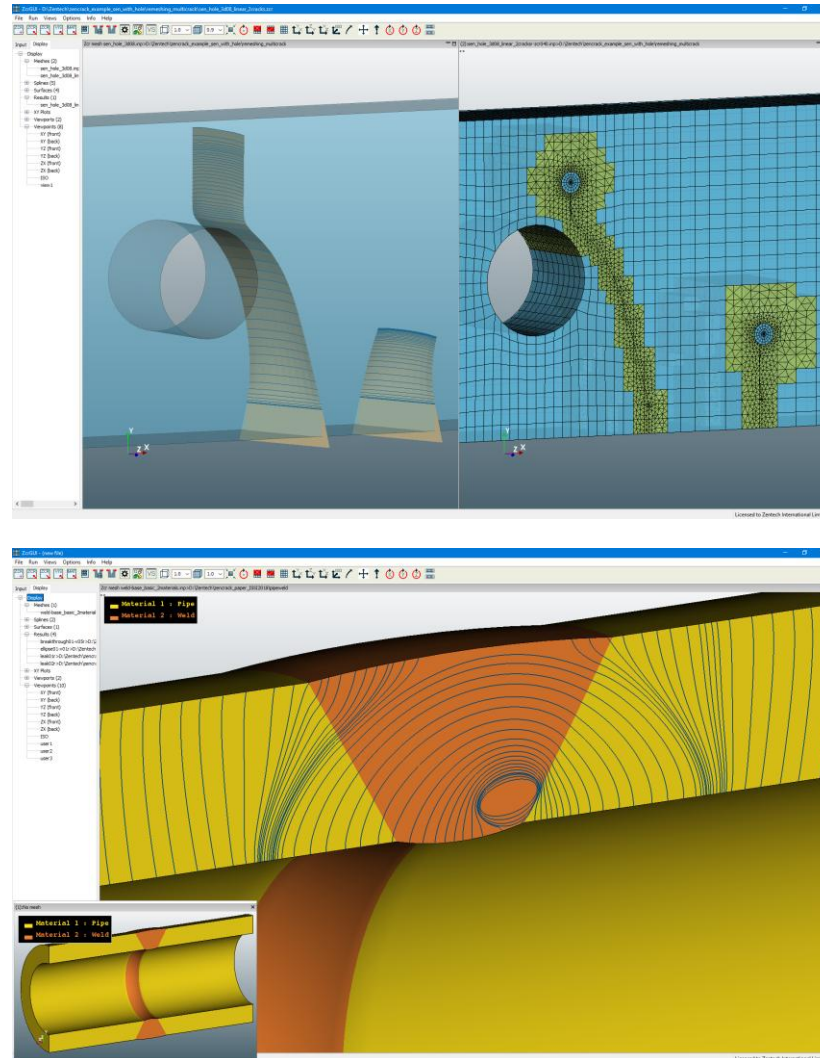

Zencrack GUI – Post-processing – xy plots

- Several xy plot types are available:

- Along a crack front
- Through the time history (i.e. multiple increments) of a finite element analysis
- Growth from multiple finite element steps
- Material input data

- Growth plots may be “snapshots” at the f.e. positions or detailed integration output
- Many variables are available for both axes
- Export of plot data to .csv files for import to Excel

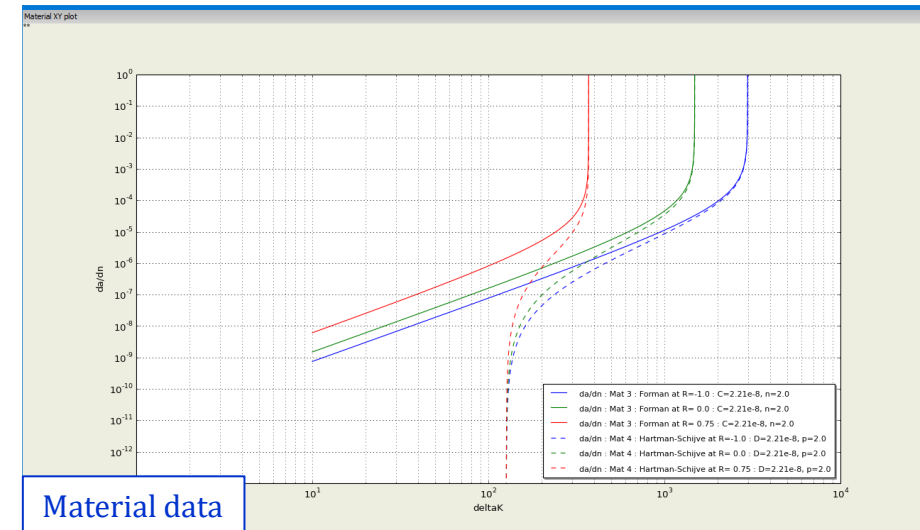
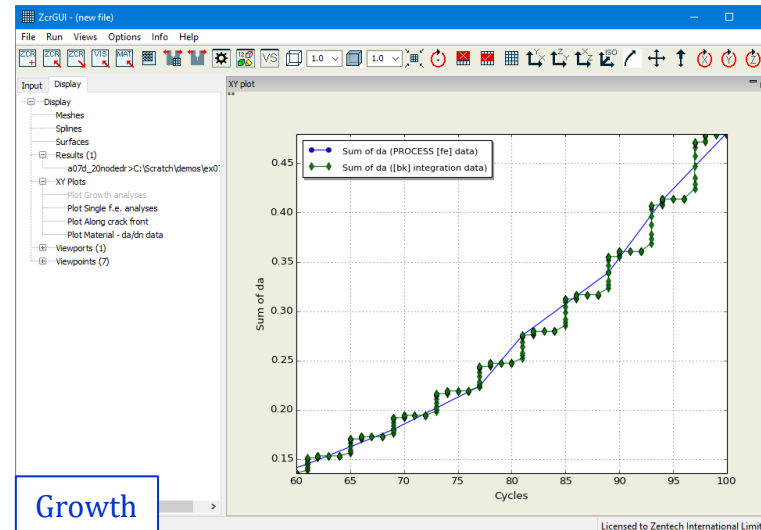
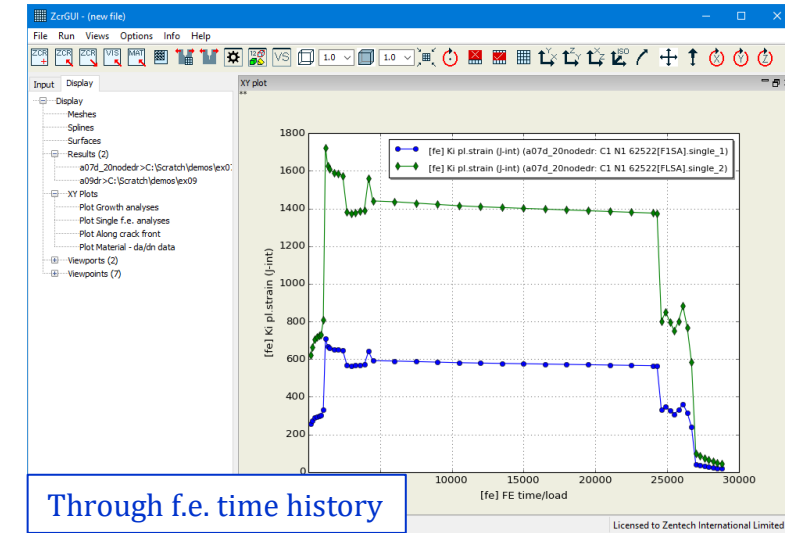
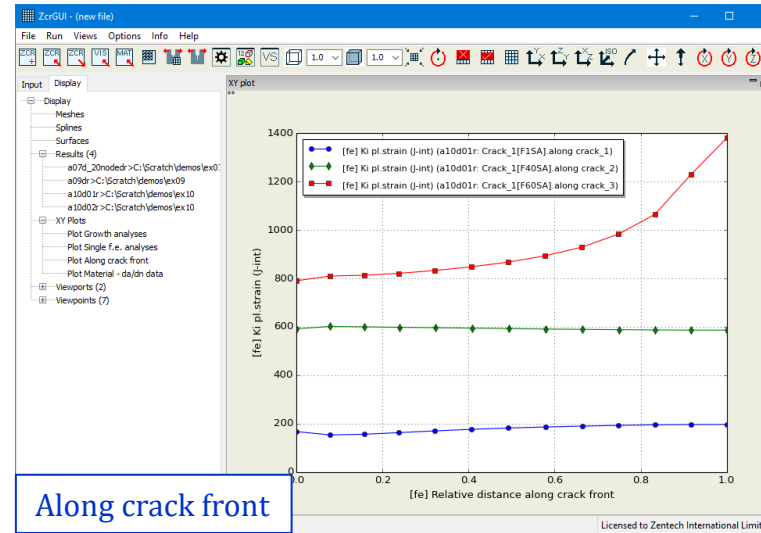

Durability and Damage Tolerance (DADT) of AM components

- Use of AM Components, Cold Spray AM materials and Cold Spray Repairs is on the increase in Defence industry specially since March 2019 (1), to enable the transformation of maintenance operations and supply chains, increase logistics resiliency, and improve self-sustainment and readiness for DoD forces.
- These processes, however, may leave micro-sized discontinuities (small cracks) affecting the fatigue life.
- US MIL-STD-1530D (2) and NASA Fracture Control Handbook NASA-HDBK-5010 (3) also mandate that requisite level of qualification, certification, and risk/safety evaluation must be carried out by an appropriate engineering support activity based on Linear Elastic Fracture Mechanics (LEFM) principles and perform predictive Durability and Damage Tolerance (DADT) assessment for all applications of AM parts/repair patches.
- Both MIL and NASA standards mandate a minimum EIDS (equivalent initial damage size) of 0.01 inch (0.254 mm) for performing durability analysis.
- The predictive assessment requires crack growth data for small and large crack regimes.

1. Under Secretary, Acquisition and Sustainment, Directive-type Memorandum (DTM)-19-006 – “Interim Policy and Guidance for the Use of Additive Manufacturing (AM) in Support of Materiel Sustainment”, Pentagon, Washington DC, March 21st, 2019.
2. MIL-STD-1530D (W/ CHANGE-1), Department Of Defense Standard Practice: Aircraft Structural Integrity Program (ASIP) (13 Oct 2016). Available online: http://everyspec.com/MIL-STD/MIL-STD-1500-1599/MIL-STD-1530D_CHG-1_55391
3. NASA-HDBK-5010, Fracture Control Handbook For Payloads, Handbook For Payloads, Experiments, And Similar Hardware (19 Oct 2017). Available online : <https://standards.nasa.gov/standard/nasa/nasa-hdbk-5010>

“BAe Systems initiative forms part of the Tempest project and will lean on additive manufacturing technologies to produce ‘significant structural parts’ of the aircraft. This demonstrator aircraft will be used to generate data that can be harnessed to support the development of the Tempest combat aircraft.



BAE Systems made the announcement at Farnborough International Airshow, detailing how the demonstrator aircraft is a ‘significant advancement’ in crewed supersonic aircraft and will boast ‘stealth features.’ The collaborators are aiming to have the demonstrator ready for flight by 2027, with a new combat aircraft set to be ready by 2035.

Harnessing 3D printing and Hot Isostatic Press (HIP) technology, BAE is hoping to produce structural parts of the demonstrator aircraft ‘efficiently and cost-effectively.’ The UK Defence Journal reports that test pilots from BAE Systems, Rolls-Royce and the Royal Air Force have conducted over 215 hours of simulation flights, which has generated information that can be leveraged to support aircraft design and future flight trials.”

By Sam Davies, 25 July 2024

Reference: <https://www.tctmagazine.com/additive-manufacturing-3d-printing-news/latest-additive-manufacturing-3d-printing-news/bae-systems-utilise-3d-printing-manufacture-tempest-demonstrator/>

Image: <https://www.baesystems.com/en-uk/product/combat-air-demonstrator>

Material Variability an Example: AM Ti-6Al-4V

Plot of 58 R=0.1 da/dN versus ΔK curves for tests on AM Ti-6Al-4V reported in (5)

Material: AM Ti-6Al-4V

LENS = Laser Engineered Net Surface

EBM = Electron Beam Melt

SLM = Selective Laser Melt

LPBF = Laser Powder Bed Fusion

DED = Directed Energy Deposition

DMLS = Directed Metal Laser Sintering

WAAM = Wire arc additively manufactured

Specimens labelled x-n refer to heat treated SLM built specimens with the crack at an angle x to the build direction, n is the specimen number, i.e. 45-2 has the crack at 45° to the build direction. Specimens with the suffix HIP, i.e. 0-6-HIP, have been hipped.

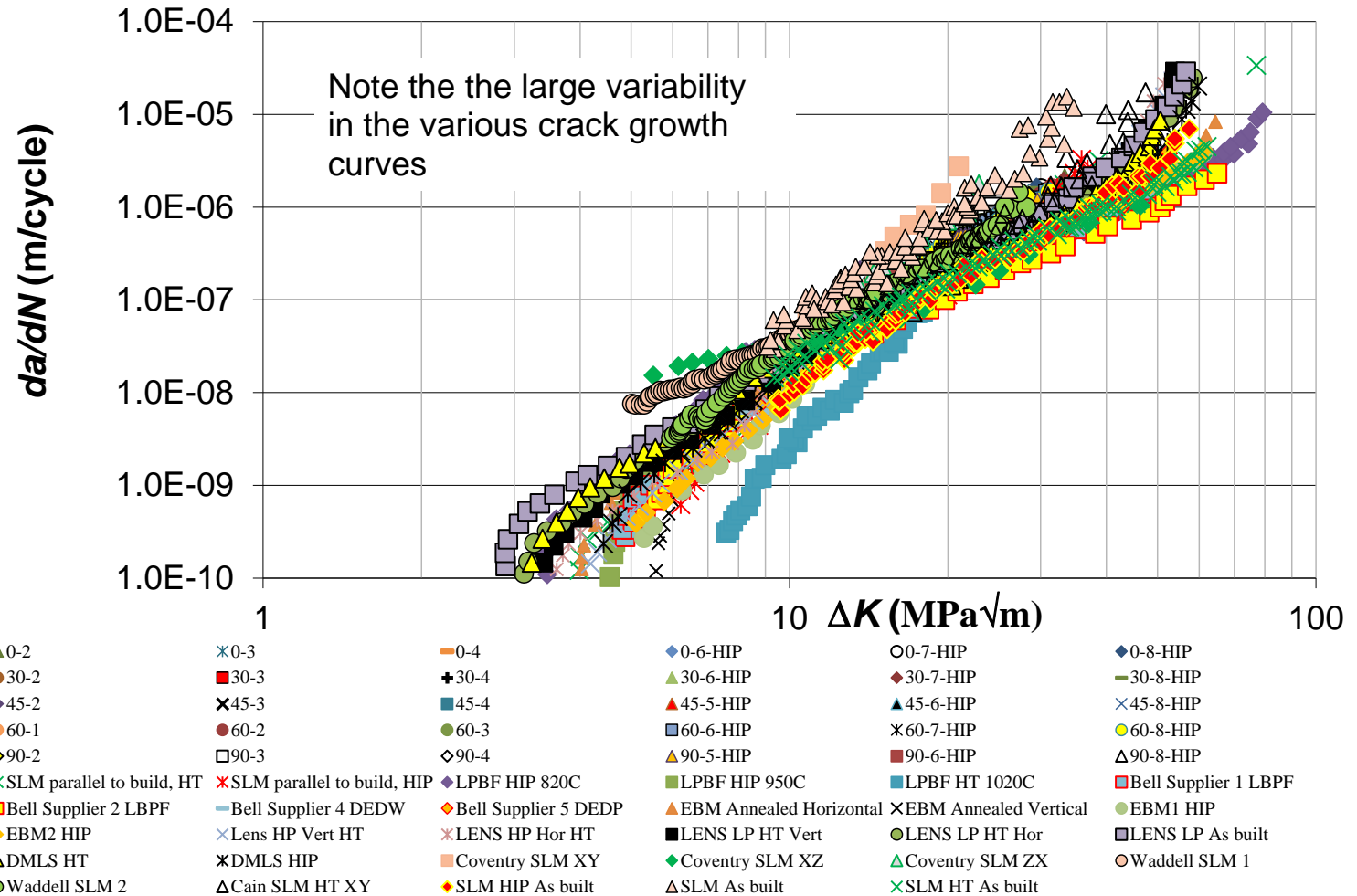

Durability And Damage Tolerance (DADT) Assessment

- A number of studies performed by US DoD and Boeing Space Agency have shown that Durability of AM, Cold Spray AM (CSAM) Materials and Cold Spray repairs appear to be controlled by only TWO Fracture Mechanics parameters for a material:
 - A the cyclic fracture toughness parameter
 - ΔK_{thr} the cyclic fatigue threshold
- The Hartman-Schijve crack growth law, a variant of NASGRO crack growth law, which is applicable to both small and long cracks is used:

$$da/dN = D (\Delta\kappa)^p$$

N is cycle number, a is crack length

D and p are material constants

Similitude constant $\Delta\kappa$ as defined by Schwalbe (4):

$$\Delta\kappa = (\Delta K - \Delta K_{thr}) / (1 - (K_{max}/A))^{1/2}$$

4. Schwalbe K.H., On the beauty of analytical models for fatigue crack propagation and fracture - a personal historical review. In Fatigue and Fracture Mechanics: 2011, 37, 3-73, doi:10.1520/JAI102713.

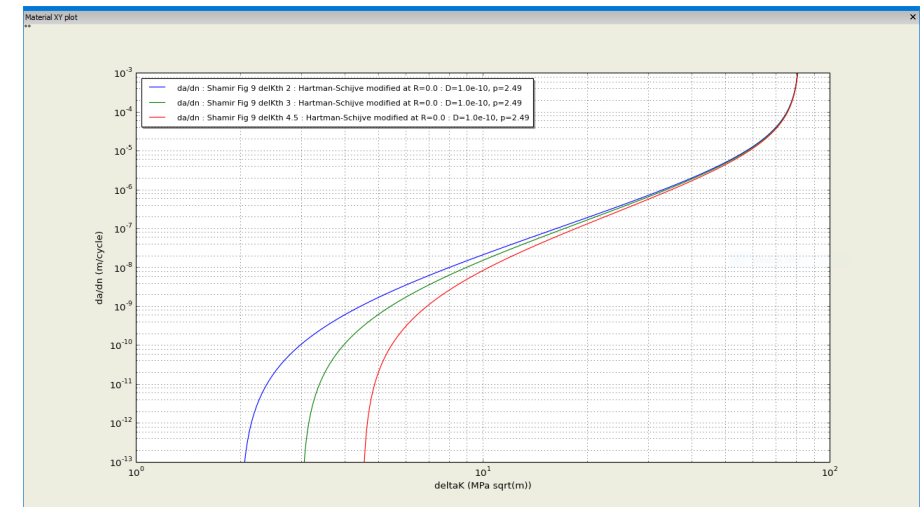

Example of Hartman-Schijve da/dN vs ΔK plots

Fitting process – example with 6 sets of test data (7)

- Calculate ΔK_{thr} and A to fit each curve while calculating D and p in the shifted $\Delta \kappa$ form for all curves:
 - General case makes no assumption about ΔK_{thr} and A values
 - Alternative approach could specify the same A for all curve fits
- Take mean of the individual curve ΔK_{thr} and A values to give final ΔK_{thr} and A
- Result is a “mean” 4-parameter curve representing all original data: ΔK_{thr} , A, D, p

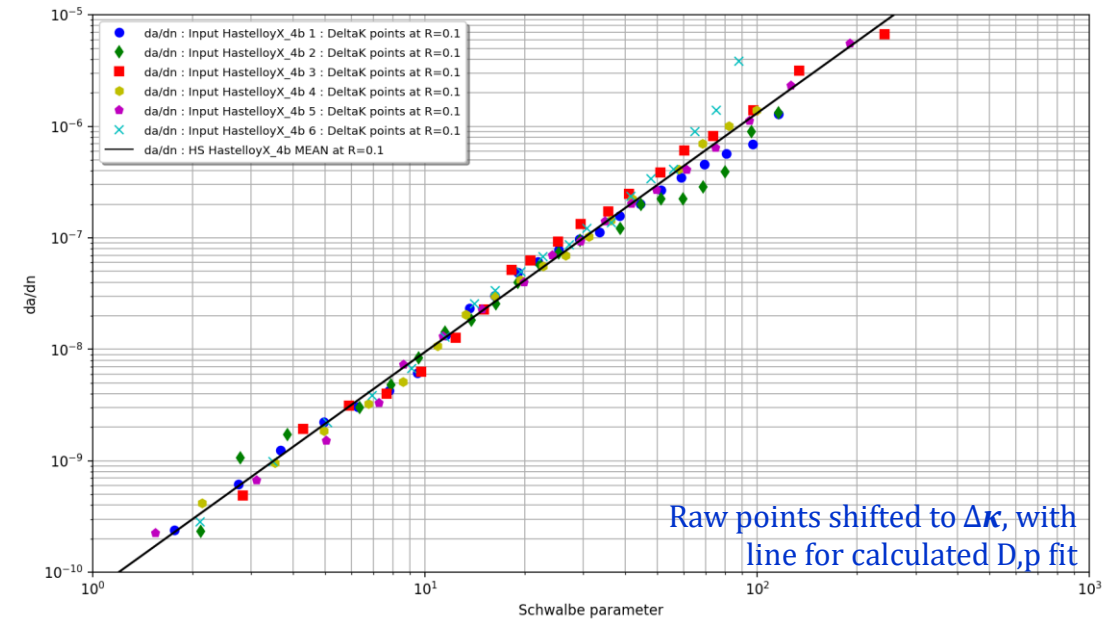
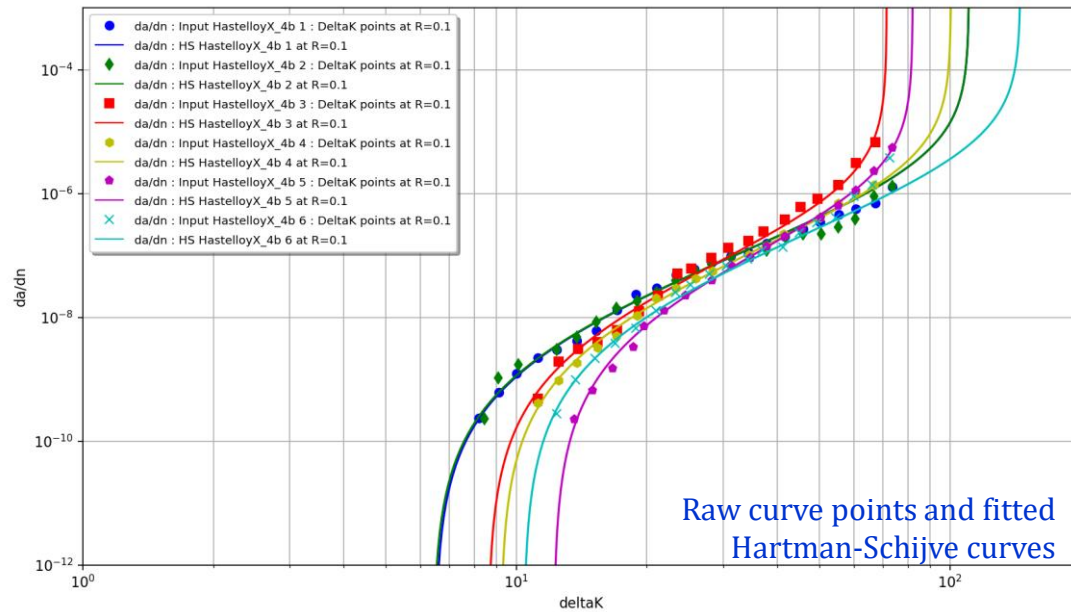

7. Fatigue crack growth in additively manufactured Hastelloy X - Influences of crack orientation and post-fabrication treatments, Karapuzha et al, Materials Science & Engineering A 854 (2022) 143773, <https://doi.org/10.1016/j.msea.2022.143773>

Example – Additive manufacturing

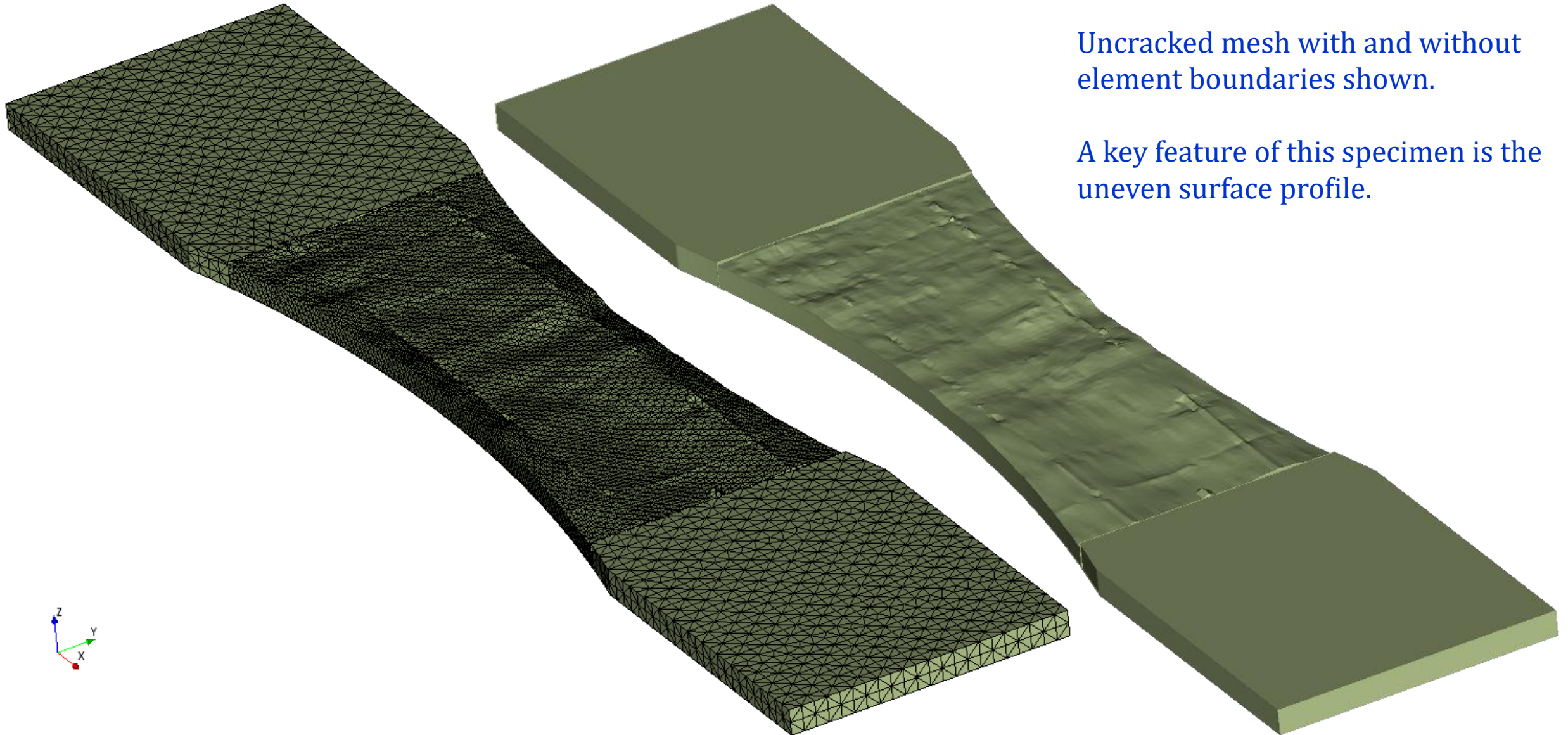

Uncracked mesh with and without element boundaries shown.

A key feature of this specimen is the uneven surface profile.

Example – Additive manufacturing



End loading is a sequence of two constant amplitude blocks.

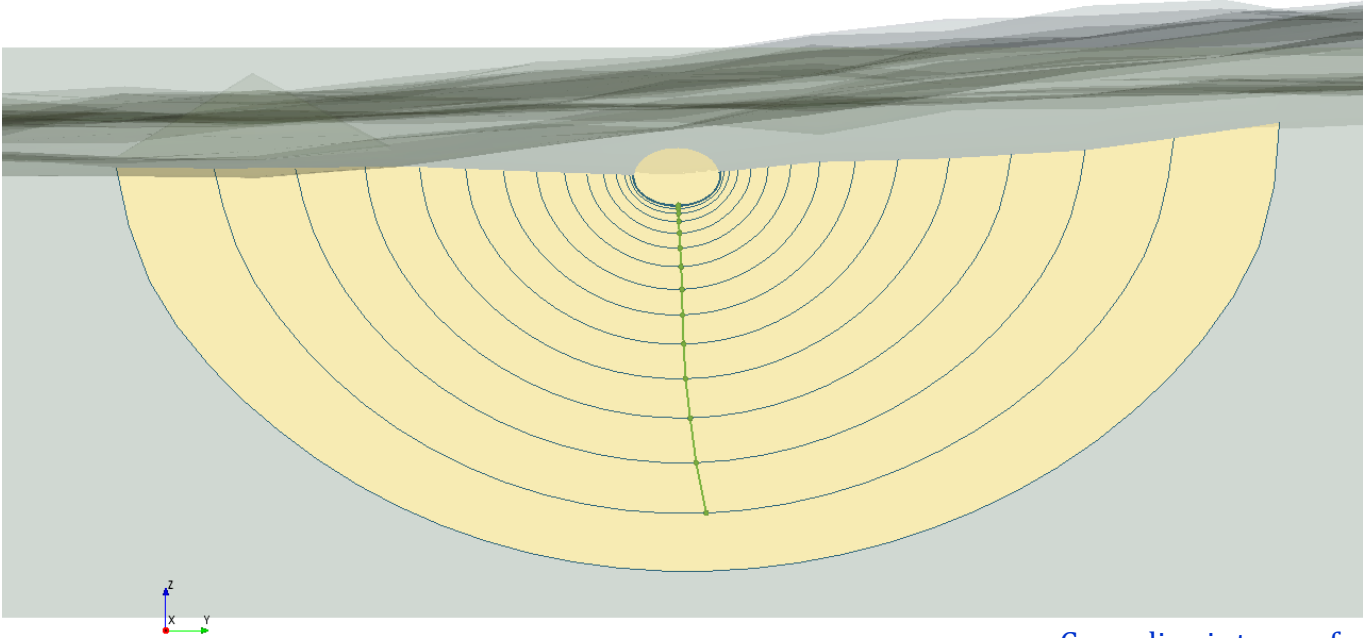
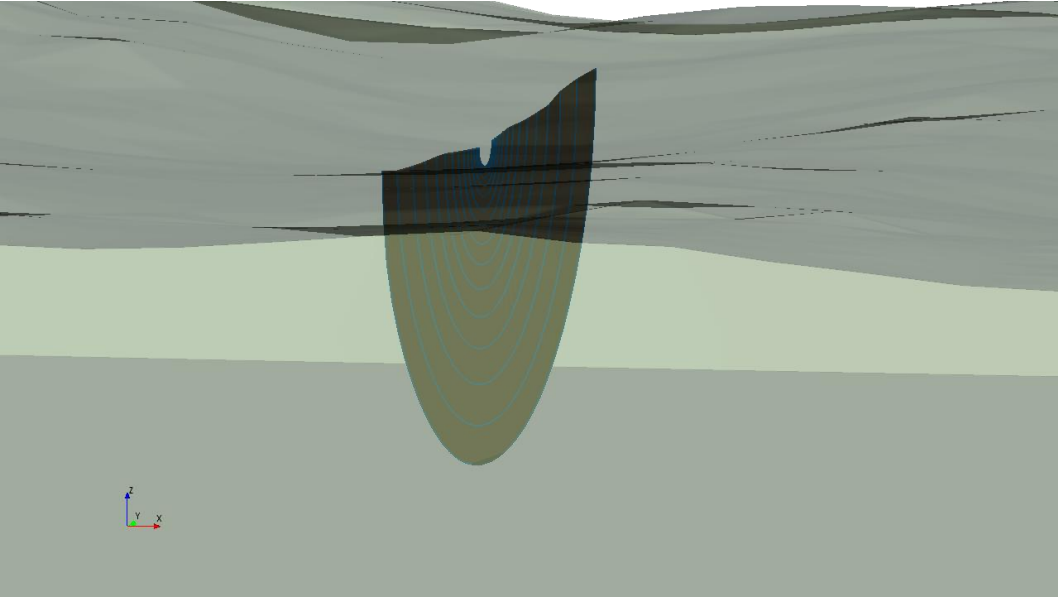

Green line is trace of middle point of the crack front used for xy plots (next slide)

Example – Additive manufacturing

- Left-hand plot shows growth vs the number of load spectrum passes
 - plot shows comparison of Paris and modified Hartman-Schijve growth laws
 - Same C,n and D,p coefficients for the two laws
- Whether the instantaneous growth rate for Paris is higher or lower than the Hartman-Schijve growth rate depends upon the ΔK value

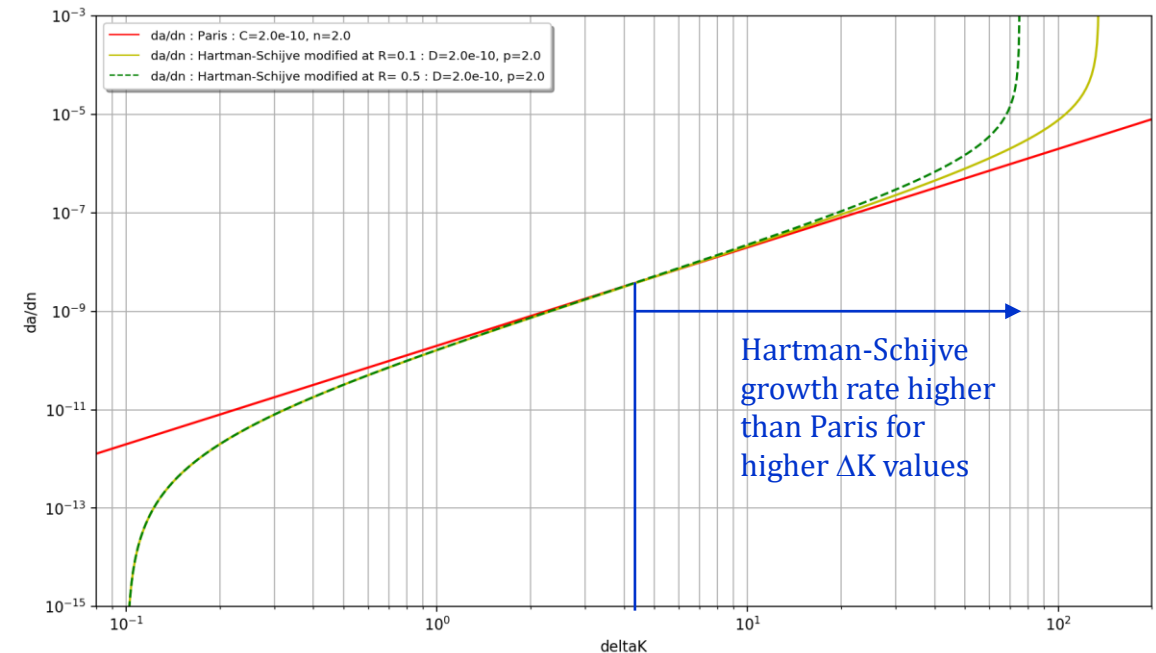
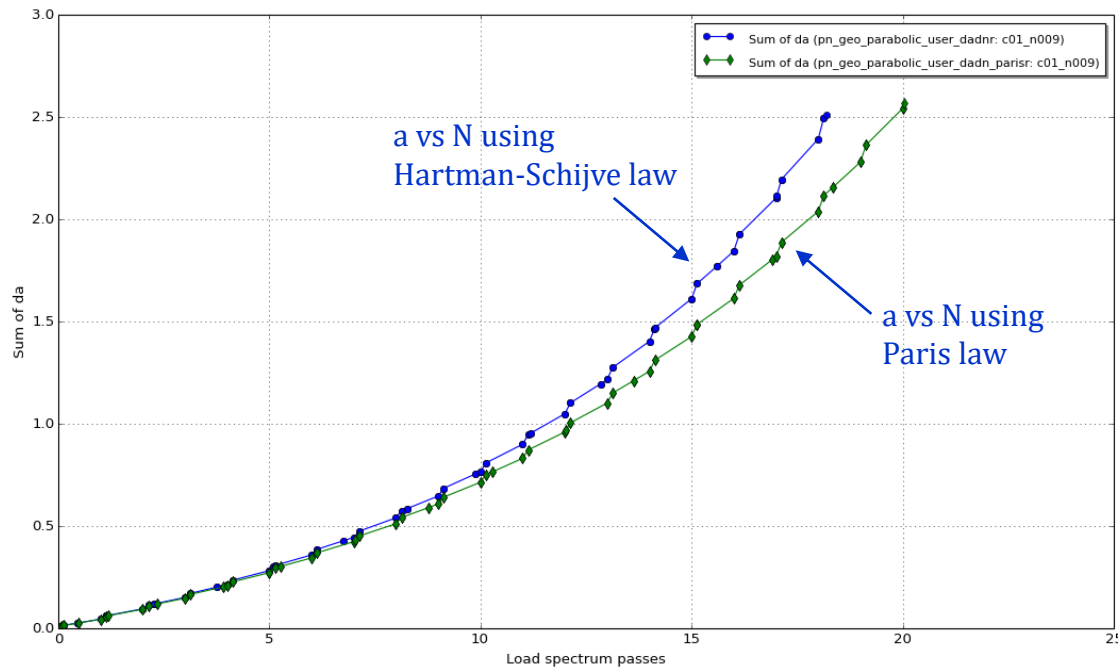

Example – Additive manufacturing – 3 cracks

- Additive manufacturing example with three cracks
- Initial cracks located near high stress regions of the uncracked component
- Modified Hartman-Schijve crack growth law

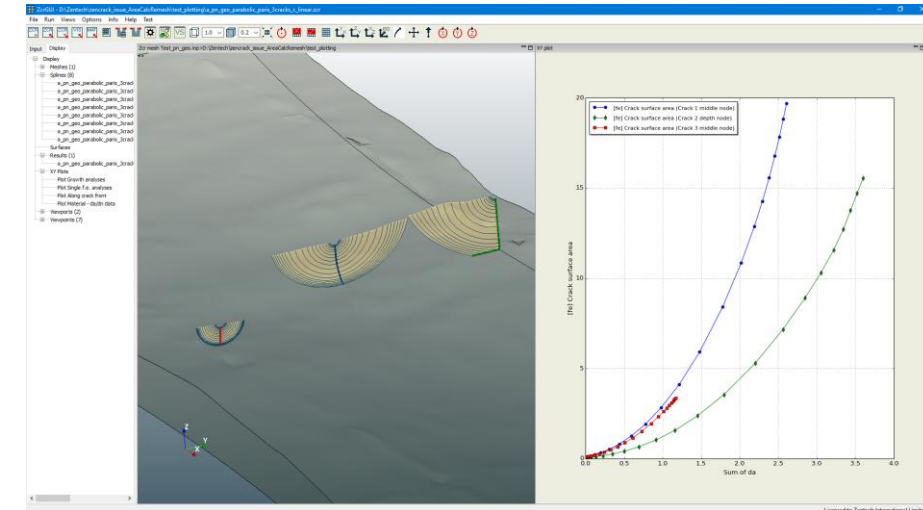
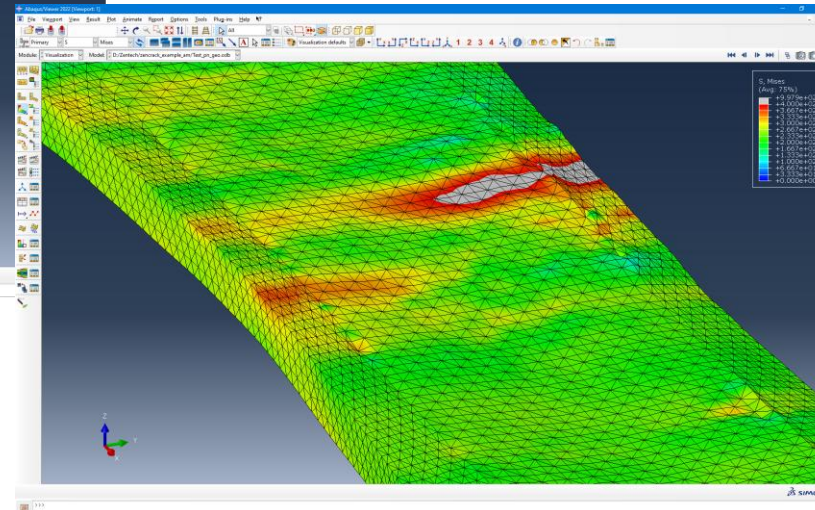
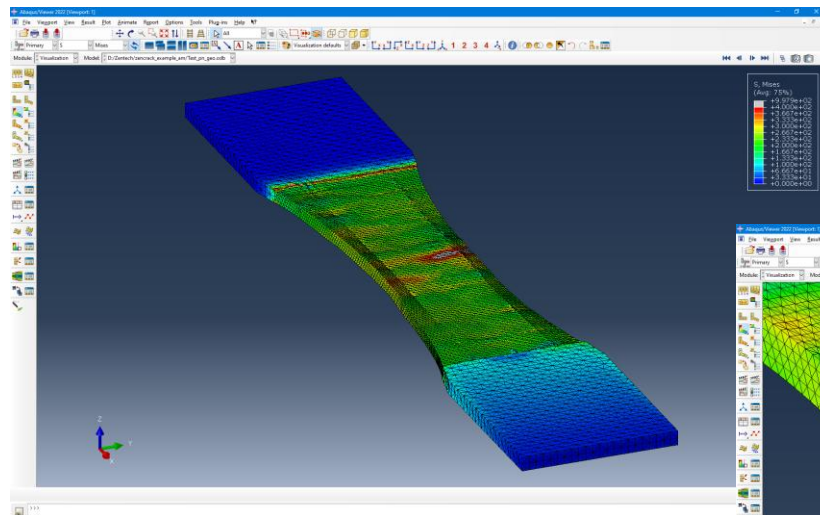

Example – Crack at root of surface pit – variation of pit ratio

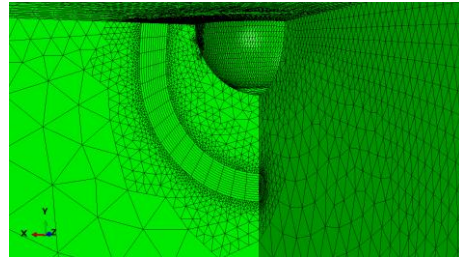
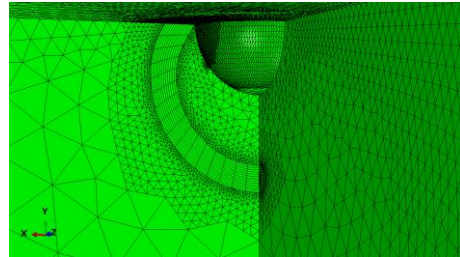
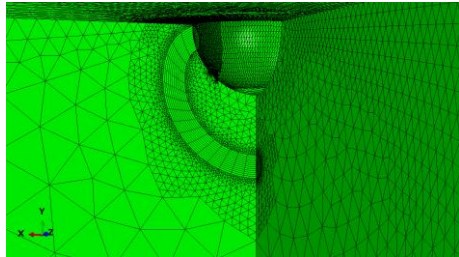
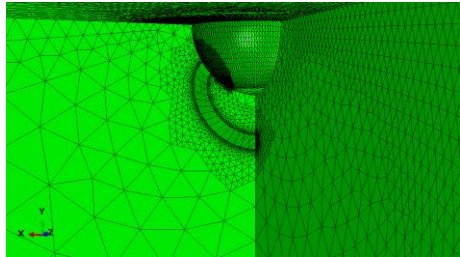
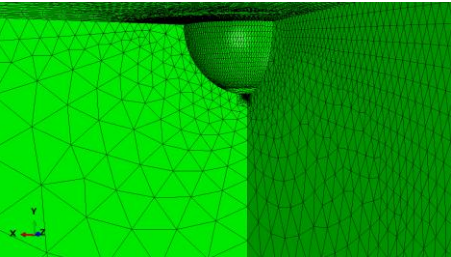
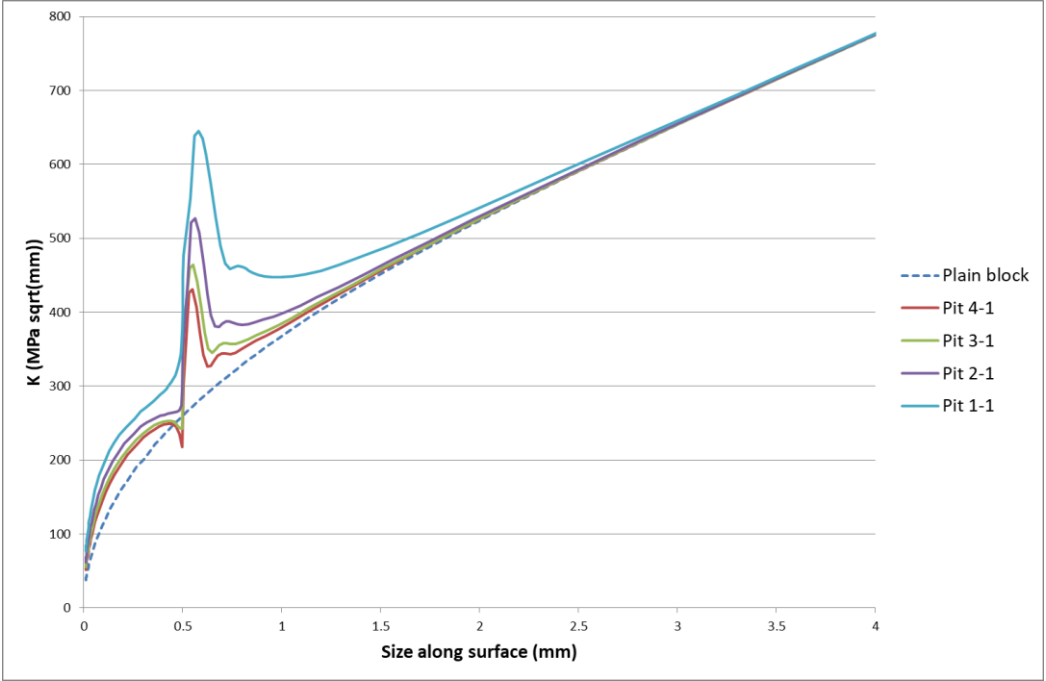
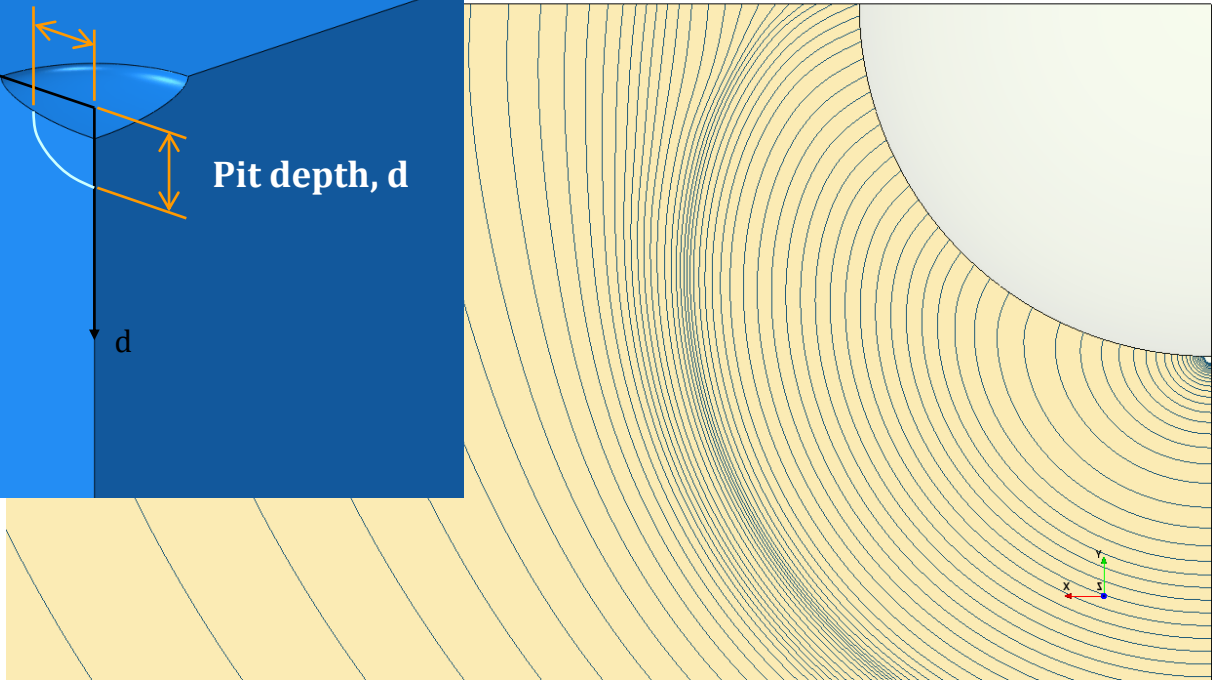
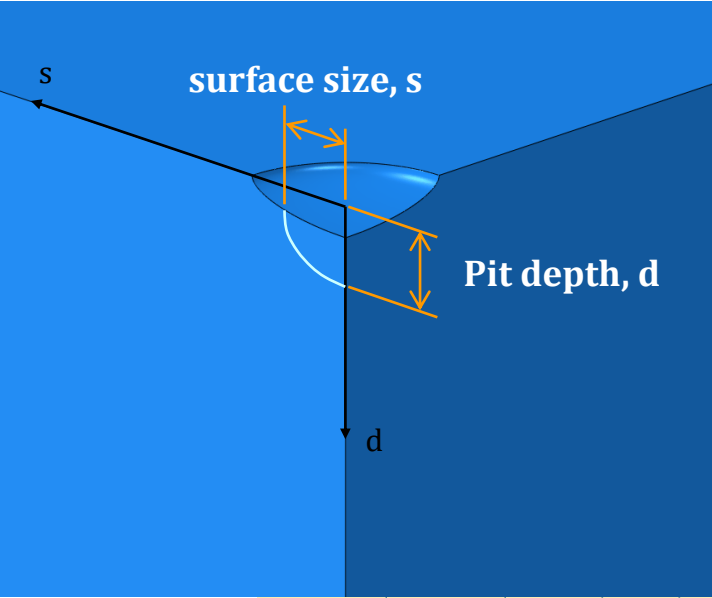

- With increased usage of AM components, Cold Spray AM materials and Cold Spray Repair Patches in Defence and Aerospace Industries, MIL and NASA Standards mandate the LEFM based Durability Analysis for the Certification to cater for small discontinuities inherent in these processes.
- It has been shown that in small crack region only two material properties matter, irrespective of the AM procedure used:
 - the cyclic fatigue threshold (ΔK_{thr}) and the cyclic fracture toughness (A).
- To achieve this, a crack growth law based on the Hartman-Schijve equation (a variant of the NASGRO equation) is proposed:

$$\frac{da}{dN} = D(\Delta\kappa)^p$$

N is cycle number, a is crack length; D and p are material constants

Similitude constant $\Delta\kappa$ as defined by Schwalbe (2) in terms of stress intensity factors (K) or energy release rate (G):

$$\Delta\kappa = \frac{\Delta K - \Delta K_{thr}}{\sqrt{1 - \frac{K_{max}}{A}}}$$
$$\Delta\kappa = \frac{\Delta\sqrt{G} - \Delta\sqrt{G_{thr}}}{\sqrt{1 - \frac{\sqrt{G_{max}}}{\sqrt{A}}}}$$

- Application of the Hartman–Schijve equation to represent Mode I and Mode II fatigue delamination growth in composites
 - R. Jones, S. Pitt, A.J. Bunner, D. Hui
 - Composite Structures, 2012, 94, 1343-1351
 - <https://doi.org/10.1016/j.compstruct.2011.11.030>
- Thoughts on the Importance of Similitude and Multi-Axial Loads When Assessing the Durability and Damage Tolerance of Adhesively-Bonded Doublers and Repairs
 - R. Jones, R. Chandwani, C. Timbrell , A.J. Kinloch, D. Peng
 - Aerospace 2023, 10(11), 946.
 - <https://www.mdpi.com/2226-4310/10/11/946>
- A framework for automating the parameter determination of crack growth models
 - A. Iliopoulos, J.G. Michopoulos, R. Jones, A.J. Kinloch, D. Peng
 - International Journal of Fatigue, 169, April 2023, 107490
 - <https://doi.org/10.1016/j.ijfatigue.2022.107490>
- This durability assessment capability is now commercially available in Abaqus, Simcenter Nastran and Ansys via Zencrack:
 - <https://zentech.co.uk/software/zencrack>



ZENTECH

Thank you.

For more information and to download an evaluation copy of Zencrack:

<https://zentech.co.uk/software/zencrack>

zentech.co.uk